

DASH NO.	SCALE MODEL NO.	DEAD WEIGHT	CAPACITY	ITEM NO.	DESCRIPTION	QTY	MATERIAL	UNIT	PART NO.	SIZE	WT.
D-72441-1	710-55-5	602 lb	5,000 lb	1	LIFT DECK SET	1	SS 304		D-36539	AS PER FACTORY ORDER	284
D-72441-2	710-55-10	641 lb	10,000 lb	2	DECK FRAME	1	SS 304		D-72442-1	AS PER FACTORY ORDER	218
D-72441-3	710-55-20	738 lb	20,000 lb	1	DECK FRAME	1	SS 304		D-36539	AS PER FACTORY ORDER	384
			10,000 lb AXLE LOAD	2	LIFT DECK SET	1	SS 304		D-72442-2	AS PER FACTORY ORDER	257
				3	DECK FRAME	1	SS 304		D-36539	AS PER FACTORY ORDER	384
				4	SPACER BAR	1	SS 304		D-73259	(MATCH DECK THK) X 4.00 X 60.00	257
				5	GAS SPRING	4	SS 316		A-73066-3		
				6	GAS SPRING	4	SS 316		A-73066-5		
				7	QUICK RELEASE PIN	4	SS 304		A-73497-2		
				8	LASH	8	SS 303		A-13067-3		
				9	LASH	4	SS 304		A-35557	0.250-20UNC X 0.50	
				10	FHSOS	8	SS 304				
				11	LOAD CELL	4	SS 304		B-36508	136-10 CH	156
				12	LOAD CELL	4	SS 304				
				13	CLAMP	12	SS 304		A-34653-1		
				14	CLAMP	12	SS 304				
				15	HHS	12	SS 304		0.375-16 UNC X 1.00		
				16	WASHER	12	SS 304		A-73699-3		
				17	WASHER	12	SS 304				
				18	EYE BOLT	2	CS		A-73698-5		
				19	SHIM	8	SS 304		A-70329		
				20	PIT ARRANGEMENT	A/R			D-72444	0.25 DECK	
				21	PIT ARRANGEMENT	A/R			D-72443	0.38 DECK	

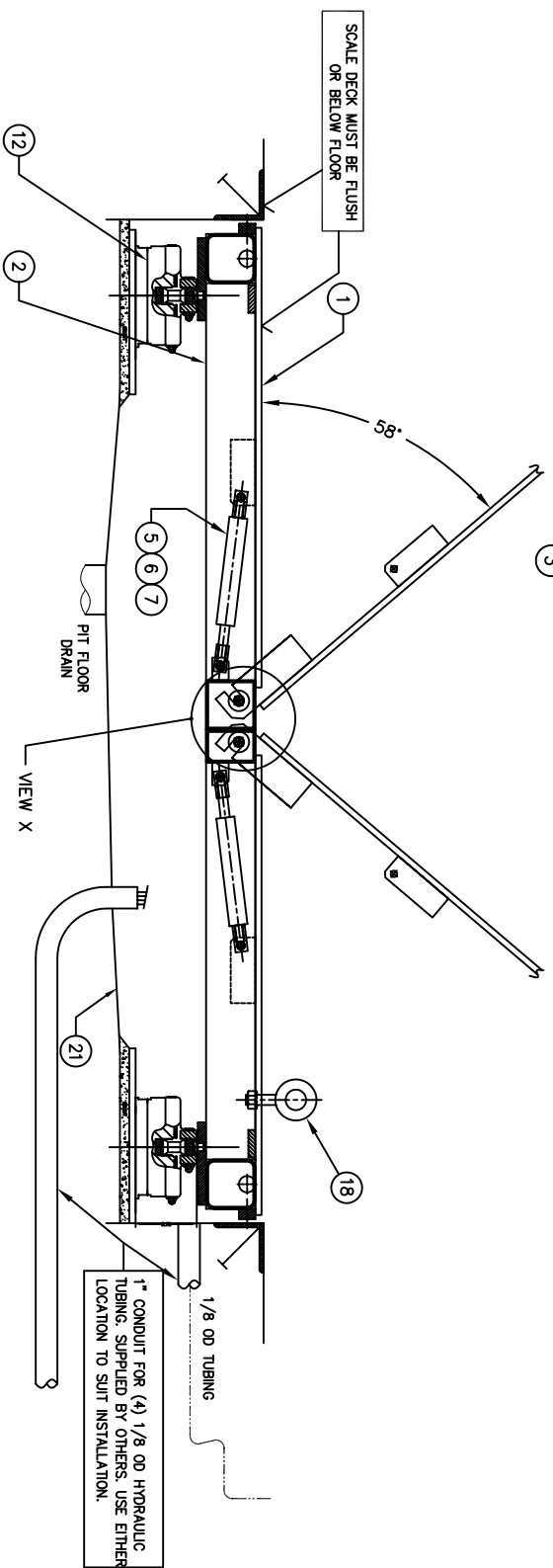

1. GAGE LOAD CELLS WITH SCALE INSTALLED
2. REMOVE NITLON SCREW
3. FILL LOAD CELL WITH FLUID TO A GAGING OF: 0.025 - 0.030 (GAP CLOSERS WHEN FILLING WITH FLUID)

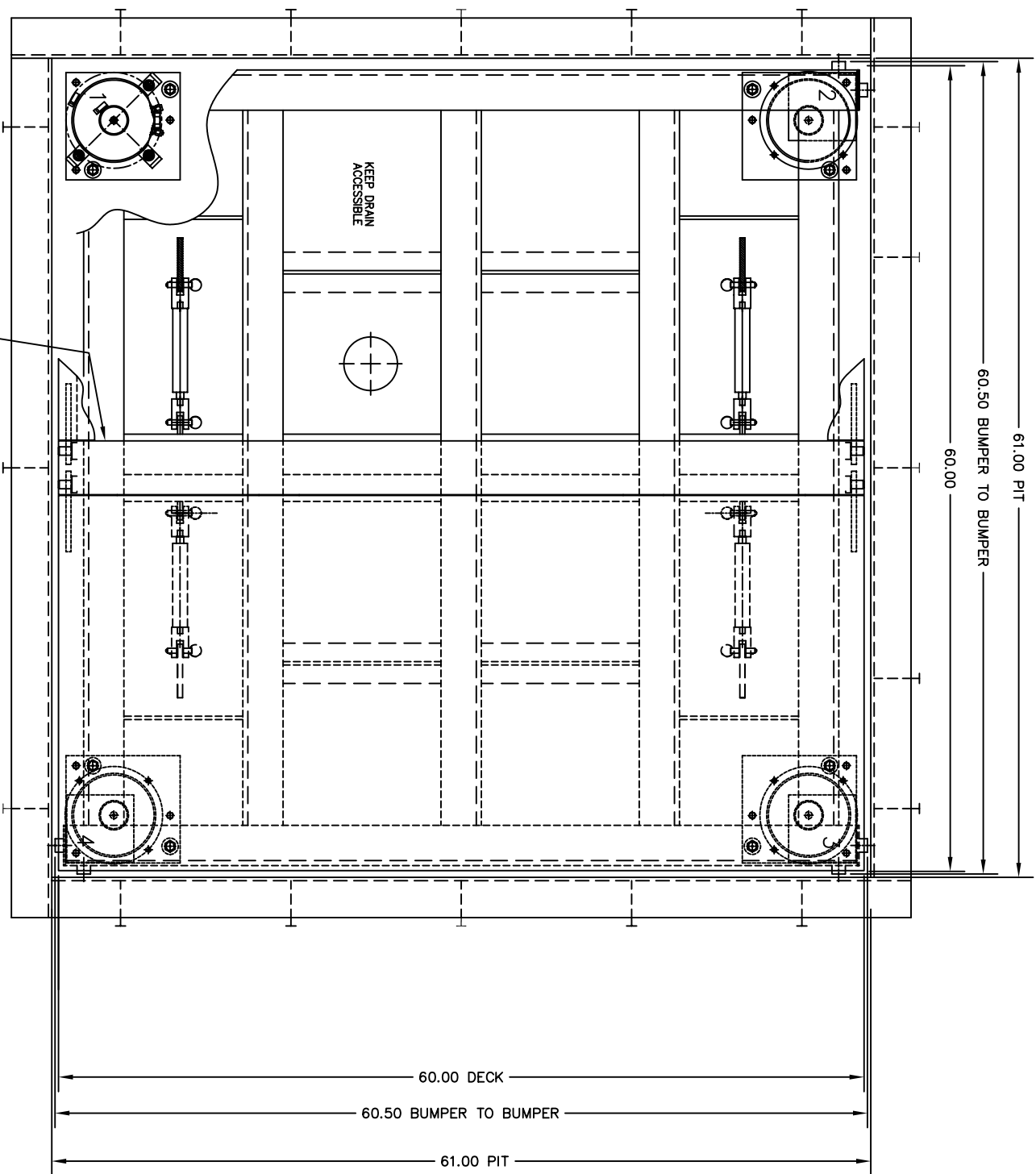
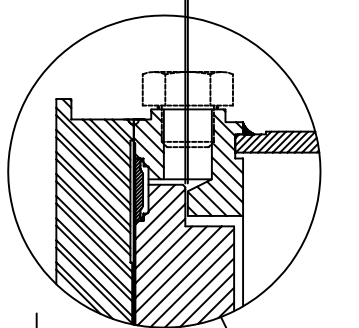

- NOTES:
1. INSTALL LOAD CELL ONTO BASE PLATES SUCH THAT FITTINGS ARE ACCESSIBLE FOR PURGING AND MAINTENANCE.
  2. RUN 1/8 OD TUBING ON PIT WALL OR PIT FLOOR IN 1/2 INCH CONDUIT.
  3. PLACE SCALE WITH DECKS AND LASHES INSTALLED INTO PIT AND CHECK FOR EVEN GAP ALL AROUND.
  4. IF GAP IS NOT CONSISTANT ALL AROUND, LOOSEN CLAMPS AND RELOCATE LOAD CELL.

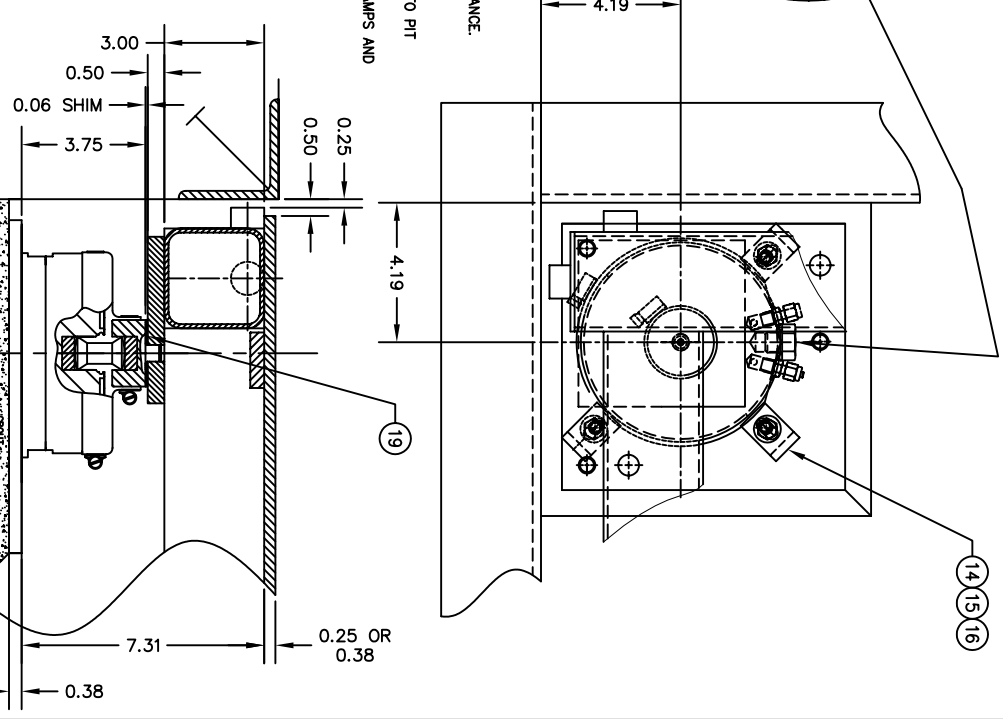
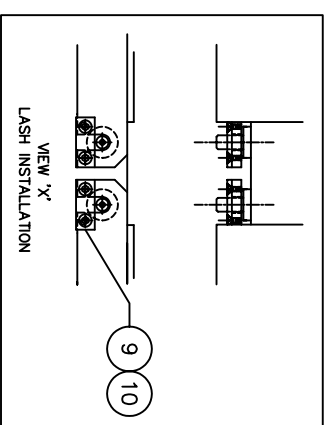

REV	DESCRIPTION	DATE	BY	CHKD	DATE
A	BASE PLATES CHANGED	2/7/01	TMC		
B	UPDATED BOM	4/9/01	BHW		

ALL SHARP CORNERS AND EDGES TO BE BROKEN DIMENSIONS ARE IN INCHES. TOLERANCES UNLESS SPECIFIED OTHERWISE: MACHINING ± .13 DRAWING ± .005

EMERY WINSLOW SCALE COMPANY  
SEBASTIAN, CT U.S.A. TERRE HAUTE, IN.

SCALE ASSEMBLY MODEL 710-55-136-10CH WITH GAS SPRING LIFT DECK

SCALE FIRST USED ON D-72441-1