



60-102

TANK SCALE

INSTALLATION and

MAINTENANCE MANUAL

**Emery Winslow Scale Company**

[www.emerywinslow.com](http://www.emerywinslow.com)

73 Cogwheel Lane  
Seymour, CT 06483

203-881-9333

Rev Nov 2005

# Table of Contents

<b>SECTION 1</b>	<b>INTRODUCTION TO COMPONENTS</b>	<b>3</b>
	Description Functional Overview Weighing System Components	
<b>SECTION 2</b>	<b>SYSTEM INSTALLATION</b>	<b>6</b>
	Installation Requirements Load Cell Installation Totalizer Enclosure Installation Tubing Installation Tube Fitting Nut Installation	
<b>SECTION 3</b>	<b>PURGING THE SYSTEM</b>	<b>12</b>
	Totalizer Components Fill the Filling Tool Preparing to Purge the System Purge the Tubing and Load Cells Gauge the Load Cells Instrumentation Hookup	
<b>SECTION 4</b>	<b>PERIODIC INSPECTION</b>	<b>18</b>
<b>SECTION 5</b>	<b>SPARE PARTS</b>	<b>19</b>
<b>SECTION 6</b>	<b>TROUBLESHOOTING</b>	<b>20</b>
	General Troubleshooting Service Information	
<b>SECTION 7</b>	<b>EVALUATION and REPAIR PROCEDURES</b>	<b>22</b>
	Totalizer Transducer Evaluation- Model 180/181 Totalizer Totalizer Transducer Replacement- Model 180/181 Totalizer Totalizer Adjustment (Cornering) Diaphragm Replacement Purge the Totalizer- Model 180/181 Totalizer	

# SECTION 1 - COMPONENT INTRODUCTION

## Description

Emery Winslow weigh scales are designed for durability and long life. They use several high precision Hydrostatic™ Load Cells and a Hytronic® Totalizer to measure the weight on the scale.

## Functional Overview

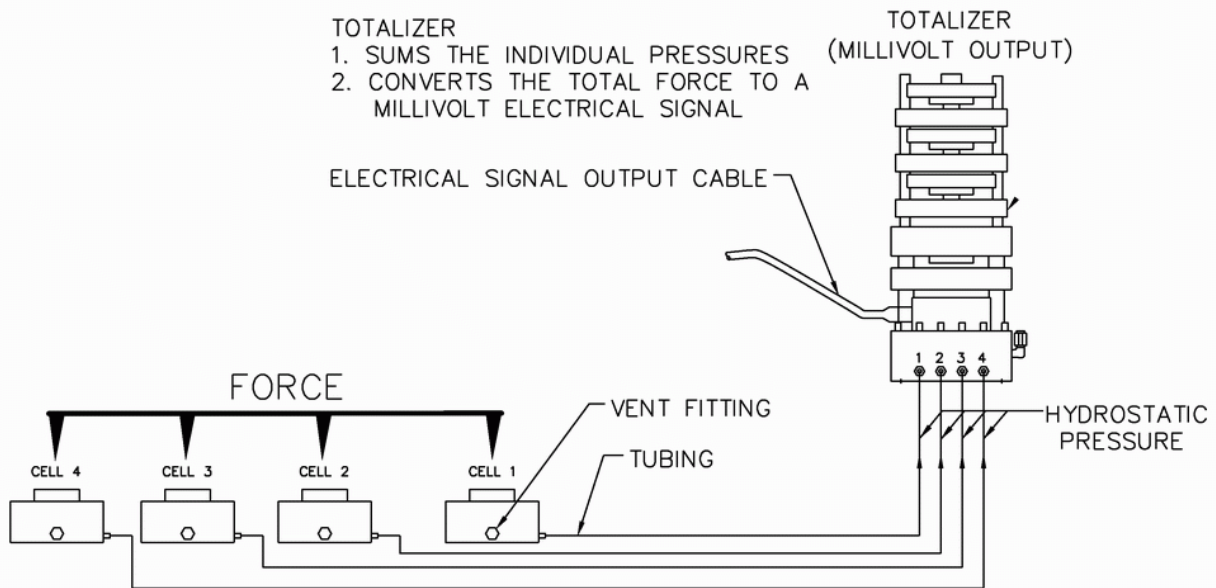

- 1) The mass to be weighed is placed on the scale.
- 2) The Hydrostatic™ Load Cells are compressed under the load and output a pressure signal.
- 3) The pressure signals are transmitted, via capillary tubing, to a Hytronic® Totalizer.
- 4) The Totalizer sums the pressure signals and outputs an electrical millivolt signal to the instrumentation.
- 5) The electrical signal is directly proportional to the weight of the mass.

## Weighing System Components- 102

**1. Lifemount Assembly:** The Lifemount Assembly, also called a Corner Assembly, consists of a Hydrostatic™ Load Cell, load plate, and base plate. Each Lifemount Corner Assembly has one load cell.

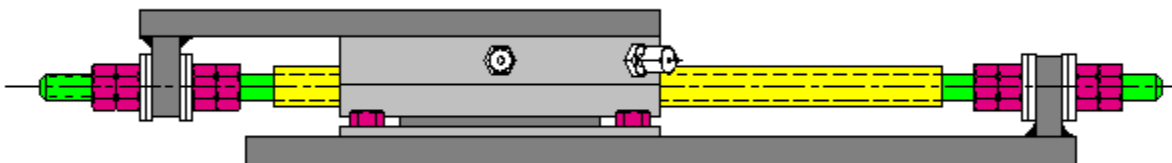

**60-102 Lifemount Assembly**

**2. Hydrostatic™ Load Cell:** The Model 102 Hydrostatic™ Load Cell consists of a piston and base assembly and a diaphragm. Four load cell systems are the most common, but the number of load cells can range from one to ten, or more.



The load cell works on the formula-

$$\text{pressure (PSI)} = \text{load (lb)} \div \text{area (sq in)}$$

The area of the cell is constant, therefore, the pressure output is proportional to the load. The vertical motion of the load cell is less than 0.010" from no load to full load conditions.

**Load Cell Gauging:** The load cell must be filled with a precise amount of cell fluid to function as designed. To determine if the cell is filled with the recommended amount of fluid, a procedure called "Gauging" is used. The process of "Gauging a load cell" is similar to gapping a spark plug. A go/no-go gauge, such as a feeler gauge, is used to precisely determine the distance between 2 points in the load cell body.

**Cell Fluid:** The typical cell fluid used in the scale is Emery Winslow BL-15. This inert blue fluid is supplied with each system as part of the accessory package.

**DO NOT** use automotive engine oil or hydraulic brake fluid.

**Filling Tool:** A filling tool is used to fill the system with cell fluid.

**3. Tubing:** The 1/8" OD tube transmits the Hydrostatic™ pressure signal from the load cell to the Hytronic® Totalizer. The tubing is thick wall capillary tubing.

Stainless steel tubing is recommended for corrosive or food process environments and is supplied standard on vessel scale systems.

**4. Fittings:** The tubing is connected with compression fittings. The fitting consists of a body, two ferrules (front and back) and a nut.

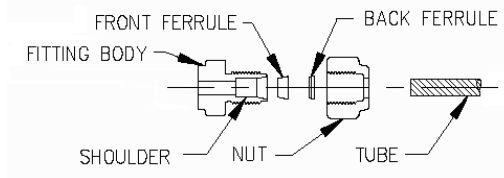

**5. Hytronic® Transducer:** In single load cell systems, the load cell output pressure is transmitted to the transducer. A transducer in the unit produces an electronic signal that is proportional to the input pressure from the load cell.

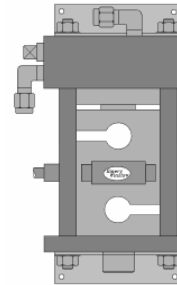

**6. Hytronic® Totalizer:** For multiple load cell systems the load cell output pressures are combined at the totalizer (summing unit). A transducer in the totalizer produces an electronic output signal proportional to the sum of the input pressures from the load cells.

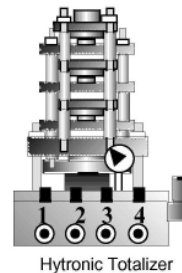

**7. Digital Indicator:** Most strain gauge digital indicators can interface with the Emery Winslow Hytronic® Totalizer. For details about the system's indicator, see the digital indicator manual.

## SECTION 2 - SYSTEM INSTALLATION

When installing an Emery Winslow vessel scale, please reference the Scale Installation Drawings in conjunction with this manual.

If you have questions, or need further assistance, please contact the Emery Winslow Service Department. We will provide assistance to ensure the installation will result in a properly functioning weigh system.

### Installation Requirements

#### **Base Plates must be installed level.**

The base plates should be level, within "bubble level", to minimize shimming. A non-shrink cement-based grout, shims, and/or leveling nuts may be required.



#### **Base Plates should be installed in the same plane** to minimize shimming.

If the installation requires the legs to be mounted on a sloped floor, the elevation of each base plate can vary in relation to the others, but each individual base plate must be installed level.

#### **LIFEMOUNT Base Plates must be anchored in place**

The base plates must be anchored in place to prevent the vessel scale assembly from moving. The typical anchor is a 1/2" x 7" Rawl Stud or epoxy anchor. Stainless steel material should be used in all food applications.

#### **Adjustable Feet Must Be Prevented From Moving After the Machine is Set Up**

If the machine has adjustable feet, after installing the LIFEMOUNT Assembly, tack weld to positively secure the foot against any rotation. The final foot adjustment should be made after the cells have been purged and filled to their required gauging.

**Failure to lock the adjustable feet in place can result in a Dangerous and Unsafe Condition, which can result in personal injury or property damage.**

## Load Cell Installation

Layout and install the base plates per the load cell installation drawings.

**Note:** When laying out base plates with motion checking/anti-lift functions, note the recommended base plate orientation on the installation drawings.

When installing the base plates, ensure they are level.

If the vessel has adjustable feet, the foot must be prevented from moving by welding. This can be done after the weighing system is installed and calibrated, but before the vessel is put in service.

### Adjusting staybars with spherical washers

A staybar is used to keep a weigh vessel in-place. They absorb any horizontal forces which tend to move the vessel.

Review the installation drawing for component alignment and recommended staybar length.

When adjusting, do not shorten or modify the staybar. System accuracy can be compromised.

After adjustment, check that the staybars can rotate around the centerline of the staybar, with no movement along the centerline.

**Note:** When tightening the nuts, the nut pressing against each spherical washer assembly must be FINGER TIGHT ONLY. The second nut is used as a jam nut. Do not move the inner nut while tightening the jam nut!

**Note:** When installing the spherical washers, be aware of the orientation of the convex and concave spherical washers and install accordingly. The convex washer contacts the bracket and the concave washer contacts the nut.

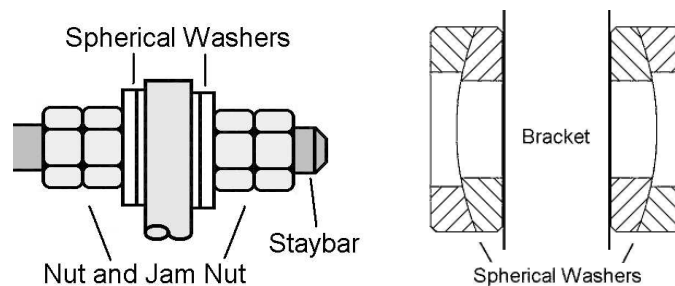

## Totalizer Enclosure Installation

The standard totalizer enclosure supplied is a Nema 4x FRP (fiberglass reinforced plastic) enclosure. Other materials such as painted carbon steel or stainless steel are available.

Besides housing the totalizer, this enclosure also serves as the field interface box for the signal cables. A terminal strip is provided for that purpose.

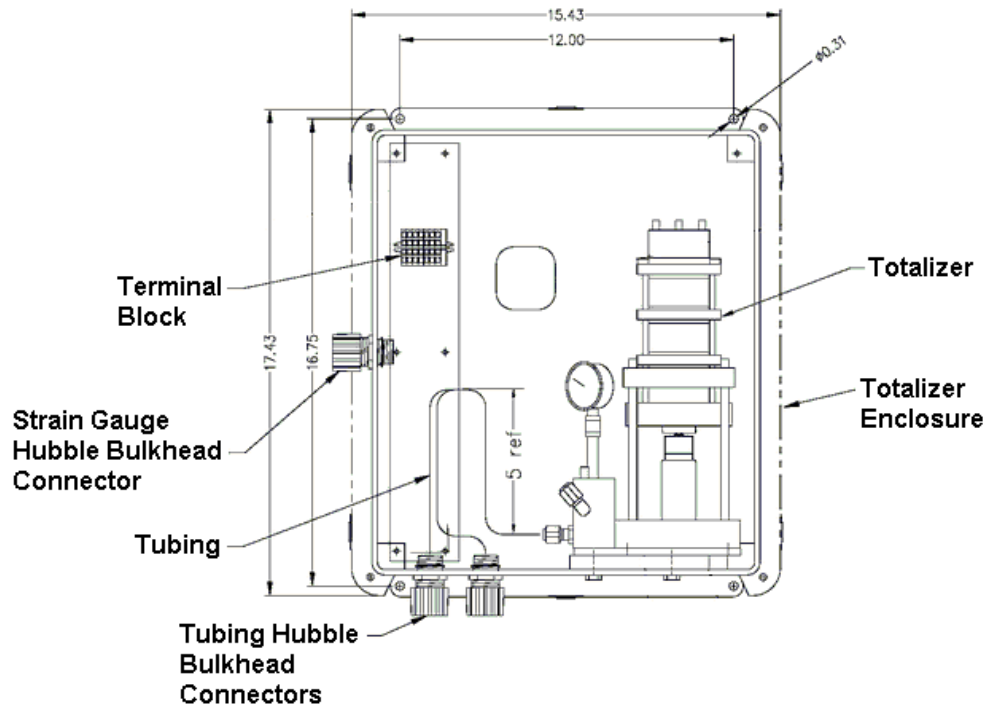

The totalizer enclosure shown is typical for a floor scale with four (4) load cells.

When laying out the installation, the totalizer enclosure should be installed as close to the load cells as possible. On a standard system, 25' of tubing per load cell is included.



## Tubing Installation

**Install the Tubing Runs** - When laying out and installing the tubing, be guided by the following notes and tubing diagram.

### Important Notes:

- A) Tubing must be protected from damage and should be run through minimum 1" diameter conduit. (Minimum 1.5" diameter for stainless tubing.)
- B) Conduit sweep(s) should have minimum 6" radius. When using stainless steel tubing, do not utilize more than (3) three 90° sweeps in the conduit run.
- C) Tubing runs should be as short as possible.
- D) When planning tubing runs, avoid steam lines and other sources of heat or cold which cause large temperature changes from ambient.
- E) In each tubing run, leave a few extra feet of tubing in the run. Coil this extra tubing and place it in a safe, accessible location. This extra tubing will facilitate making a new connection at the load cell or totalizer if needed.
- F) When cutting the tubing, use a good quality pipe cutter to produce a clean and burr free end for the Nut and Ferrules to slide over. Do not use any type of pincher cutter to cut the tubing. After cutting the tubing, inspect the cut end for any burrs. Use a fine, hard file to remove the burr from the edge of the tubing. Check the tubing bore to make sure it has not been pinched closed during the cut.
- G) Install the tubing through the totalizer enclosure's bulkhead connector **BEFORE** installing the fitting nut on the end of the tubing.
- H) A brass fitting must never be used with stainless steel tubing. Brass is not strong enough to make a leak-proof connection.
- J) The totalizer should not be mounted more than four (4) feet above the scale.

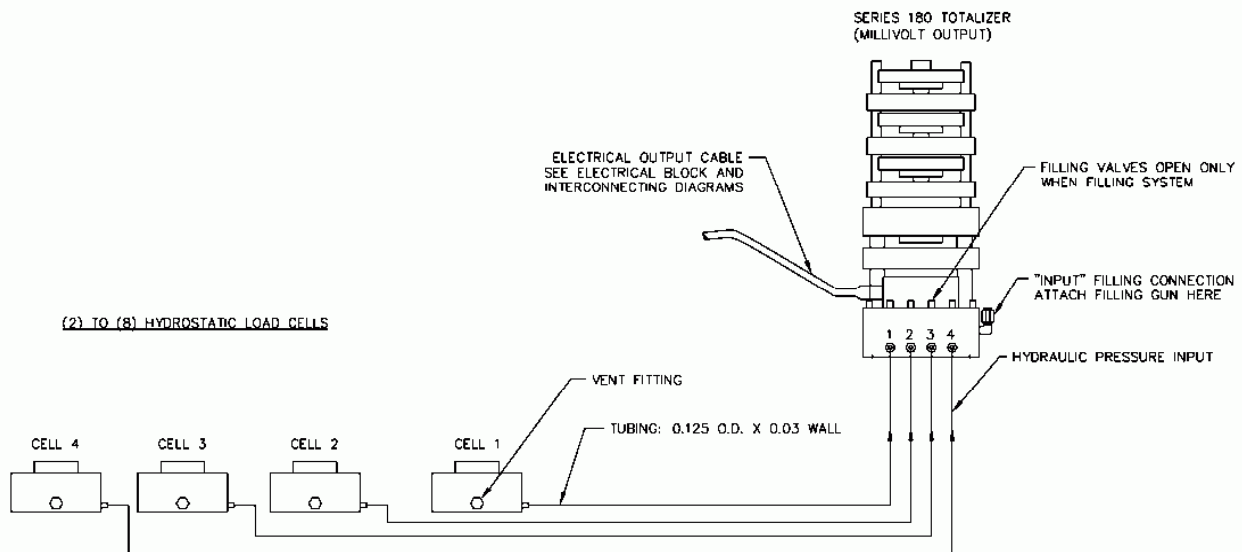

### **Tube Fitting Nut Installation**

Each load cell has two fittings. They are interchangeable in their function. One connects to the tubing and the other is used to purge the cell of air during start up and maintenance. Connect the tube to the fitting that provides the most protection for the tubing. The other fitting then becomes the purge fitting.

When installing the fitting nut on the tubing, please see the installation instruction on drawing A-34055, shown on the next page.

**IMPORTANT** Install the tubing through the totalizer enclosure's bulkhead connector before installing the fitting nut on the end of the tubing.

If the nut and ferrules do not slide over the tubing, use a fine hard file to remove the burr from the edge of the tubing.

**To continue the installation process, go to Section 3.**

A-34055

The tubing connections between the load cells and the totalizer are important to the installation of an Emery Winslow Hydrostatic Scale system. Making these connections is more simple than tubing a brake line on an automobile and just as important.

This connection utilizes a "Double Ferrule" design. Each fitting includes a Fitting Body, a Front Ferrule, a Back Ferrule and a Nut.

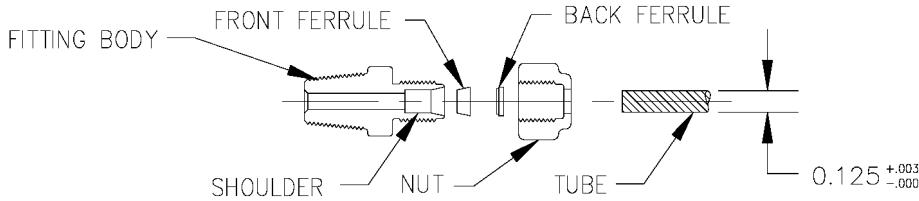

The cut tubing end should not be deformed. For stainless tubing use tube cutters with "RIDGID" #3469 wheel for 0.125 dia tubing. Use "KLEIN" #1004 cutters with spring for copper tubing only. Check the inside diameter of the tubing to be sure it is clear of any burrs and unrestricted.

Slip the Nut, Back Ferrule and Front Ferrule onto the cut end of the tubing as shown in VIEW A.

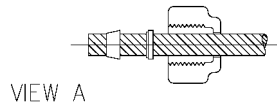

Emery Winslow recommends to pre seat the fitting as follows:

1. Clamp a Fitting Body with a vise or vise grip at its hexagon. Pre seat tubing, Nut and Ferrules.
2. This pre seating Fitting Body must be discarded after use.

Insert the cut tube end into the Fitting Body. Make sure that the tubing rests firmly on the shoulder of the Fitting Body. Tighten the Nut finger tight.

Before further tightening the Nut, scribe it at the 12 o'clock position as shown in VIEW B.

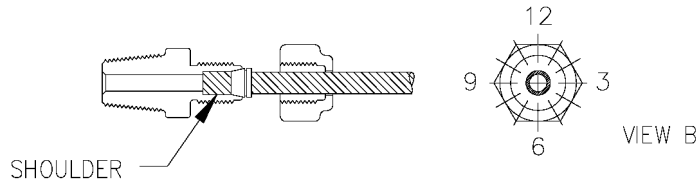

For Stainless Tubing check at 5 o'clock position that the connection feels "snugged down", for Copper Tubing check at 7 o'clock position, otherwise turn one or two more clock positions further. Do not over tighten!

Final Connection: Place pre seated Fitting into Body. Tighen the Nut finger tight. With wrench tighten by rotating the nut 3 clock positions.

EMERY WINSLOW SCALE CO.  
SEYMOUR, CT. USA  
TERRE HAUTE, IN.

DOUBLE FERRULE FITTING  
INSTALLATION INSTRUCTIONS

SCALE 1:1  
FIRST USED ON A-34055  
DRAWING NO. A-34055  
REV. A

ALL SHARP CORNERS AND EDGES TO BE BROKEN

DIMENSIONS ARE IN INCHES. TOLERANCES UNLESS SPECIFIED OTHERWISE:

MACHINING: .XX = ± .01  
FABRICATION: .XXX = ± .005

DRAWN DATE 11/21/01

CHECKED DATE

ACAD FILENAME: ACC0885

LAYERS USED: ALL

CBM 11/21/01

BY DATE

REVISION

REDRAWN ON CAD, WAS "B" SIZE

THIS DRAWING IS THE PROPERTY OF EMERY WINSLOW SCALE CO SEYMOUR, CONNECTICUT. THE INFORMATION CONTAINED HEREIN IS CONFIDENTIAL AND IS NOT TO BE USED OR DISSEMINATED TO OTHERS WITHOUT THE EXPRESS WRITTEN CONSENT OF EMERY WINSLOW SCALE CO.

## SECTION 3 - PURGING THE SYSTEM

### Totalizer Components

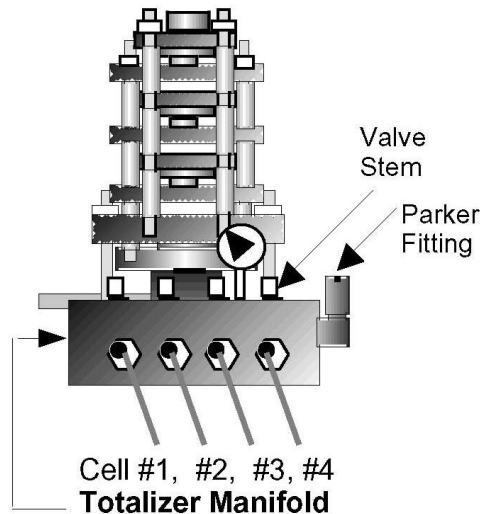

The **Totalizer Manifold** directs the hydrostatic cell fluid from the totalizer cells to the individual load cells. Looking at the face of the manifold, cell #1 is connected to the left fitting. Cell #2, #3 and #4 are connected to the 2nd, 3rd and 4th fitting as illustrated.

The **Parker Fitting** is used to add or remove cell fluid from the individual load cell circuits. The Filling Tool is attached to the Parker Fitting to fill the system.

The **Valve** for the individual fitting is located directly above the fitting. The valve opens or closes the individual load cell circuits to the Parker Fitting. Refer to the schematic diagram below.

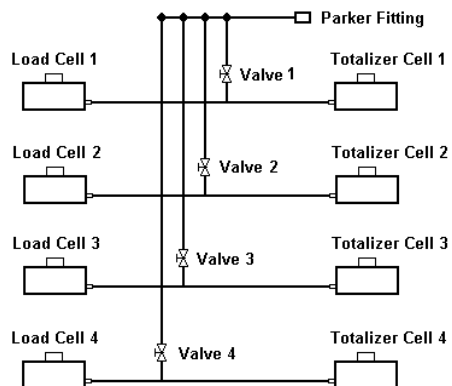

When Valve #1 is open, fluid from the Parker Fitting flows into the tubing circuit connecting Totalizer Cell #1 to Load Cell #1.

**Note: Do not open more than one (1) valve at a time. Unpredictable results can occur.**

The valve wrench is used to open and close the valve.

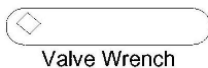

### Fill the Filling Tool

Pull out the T-handled follower rod. When it is fully extended pull the rod sideways to latch the groove of the rod into the key hole slot of the cap.

Remove the head from the filling tool.

Fill the filling tool with Cell Fluid to within one inch of the top.

Reassemble the filling tool. Screw the head on tight. Release the follower rod.

Holding the head up, open the Purge Fitting slightly to let the air escape. Keep it open until oil flows out.

While holding the head end up, pump the handle several times to clear the pump and the connecting tube of air. The Filling Tool is now purged and ready.

During use check for free travel of the follower rod frequently by pulling the rod outward. If the follower rod has one inch or less of free travel fill the Filling Tool again. An empty Filling Tool will fill the system with air and cause weighing errors.

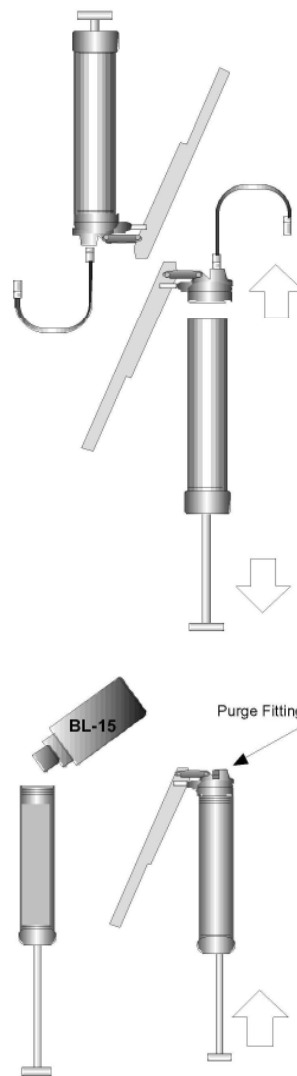

### Preparing to Purge the System

Before shipment from the factory all of the fluid cavities of the Totalizer were purged of air and filled with hydrostatic cell fluid. Tubing and Load Cells are not filled at the factory. The procedure for purging a new system and an existing system are the same.

**Note:** Remove the manifold fitting caps from the manifold fittings only when attaching the tubing. **DO NOT LIFT OR MOVE THE TOTALIZER WITH THE FITTING CAPS REMOVED!** Air could be introduced into the totalizer cells requiring a totalizer purge.

### Purge the Tubing and Load Cell

Attach the Filling Tool to the Parker Fitting. Remove the cap from the Parker Fitting on the side of the Totalizer Manifold. Screw on the Filling Tool Hose by using the swivel nut on the hose. **After filling the system this cap must be replaced.**

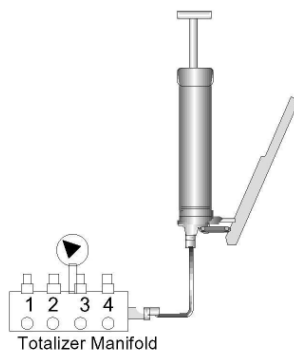

Connect the tube from each load cell's location to the corresponding fitting on the Totalizer Manifold. Do not connect any of the tubes to the load cells. Reference the tubing diagram previously shown.

Start with Cell #1's fitting (the inside fitting) and proceed until all the tube lines are connected. This sequence allows room to tighten each fitting without interference from the next one.

Purge each of the tubing lines by opening the valve and pumping cell fluid through the tube until the flow is free of air. Catch the purged cell fluid in a clean container. Close the valve after the tube is purged.

**Note: Do not open more than one (1) valve at a time. Unpredictable results can occur.**

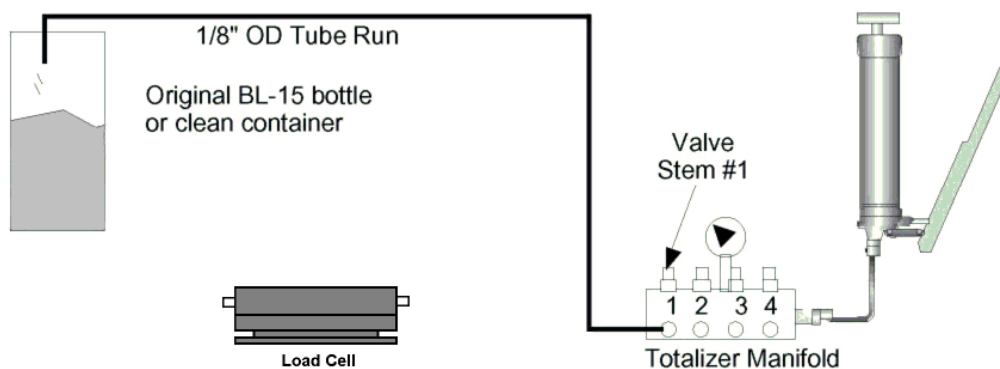

To purge the cell, connect the tubing to the fitting on the load cell. Remove the cap from the purge fitting of the cell and attach the purge line. Place the other end in a container.

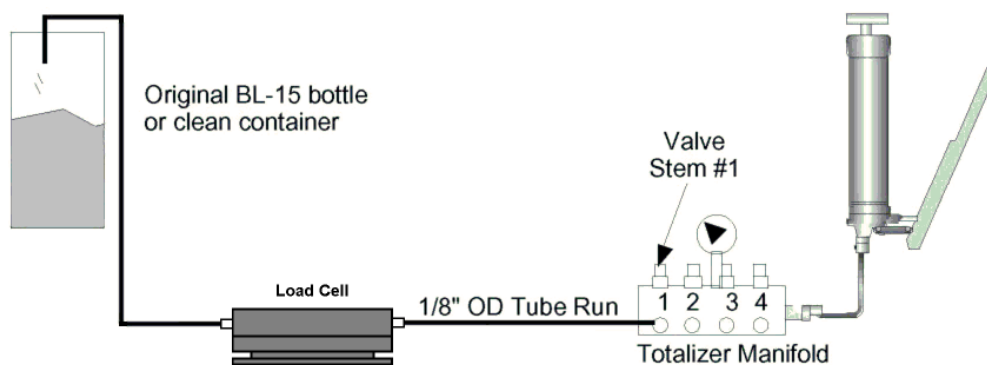

Open the corresponding valve and pump the fluid through the tubing and the load cell until the flow is free of air bubbles. Close the valve. Remove the purge line and replace it with the fitting cap. Tighten the cap while fluid is seeping out of the connection.

**Tip:** When the flow is first clear of air, stop pumping for about 5 to 10 seconds. Tap the load cell, then start pumping again. To purge a load cell completely, you may need to perform the pump/tap cycle several times.

**Note:** The captured cell fluid can be reused if it is not contaminated. If the captured cell fluid is contaminated with dirt or other fluids, dispose of in accordance with applicable regulations.

### Gauge the Load Cell- 102

To fill each load cell, open the valve and pump additional fluid into the system circuit until the recommended feeler gauge reading is reached. As you pump fluid into the cell the gauging gap will increase on the load cell. After the cell is gauged to the recommended gauging, close the valve.

If the cell is accidentally overfilled you can remove fluid by slightly loosening the purge fitting cap. This will let the cell fluid leak out slowly.



The load cell must be filled with the fluid to the recommended gauging. Consult the installation drawing supplied with your system.

Typical load cell gauging is listed in the chart below:

Model Number	Capacity	Part Number	Gauging
102-1.5-M1	1,500 lb	B-34326	1/8" $\pm$ 1/32"
102-2.5-M1	2,500 lb	B-34326-1	1/8" $\pm$ 1/32"
102-3.5-M1	3,500 lb	B-34326-2	1/8" $\pm$ 1/32"
102-5.0-M2	5,000 lb	B-34321	3/16" $\pm$ 1/32"
102-10.0-M2	10,000 lb	B-34321-1	3/16" $\pm$ 1/32"

Record the final gauge reading for each load cell in the system.

Remove the Filling Tool and replace the cap on the parker fitting.

**Note:** Remove any excess fluid from the fittings on the totalizer manifold and load cell. This will allow prompt detection of leaks should they occur.



## Instrumentation Hookup

The electrical output of the weigh system is a millivolt level signal. Typically, a terminal strip is located in the totalizer enclosure to allow wiring the weigh system to a digital indicator or process control instrumentation.

The color code for the totalizer transducer cable is:

4 wire transducer	
Red	+ excitation
Black	- excitation
Not wired	+ sense
Not wired	- sense
Green	+ signal
White	- signal

Reference the indicator or process instrumentation manual to determine the proper load cell cable hookup. A typical wiring diagram for a digital indicator is shown below.

**Note:** If Emery Winslow supplied the weight indicator as part of the system, reference the wiring diagram included with the system manual.

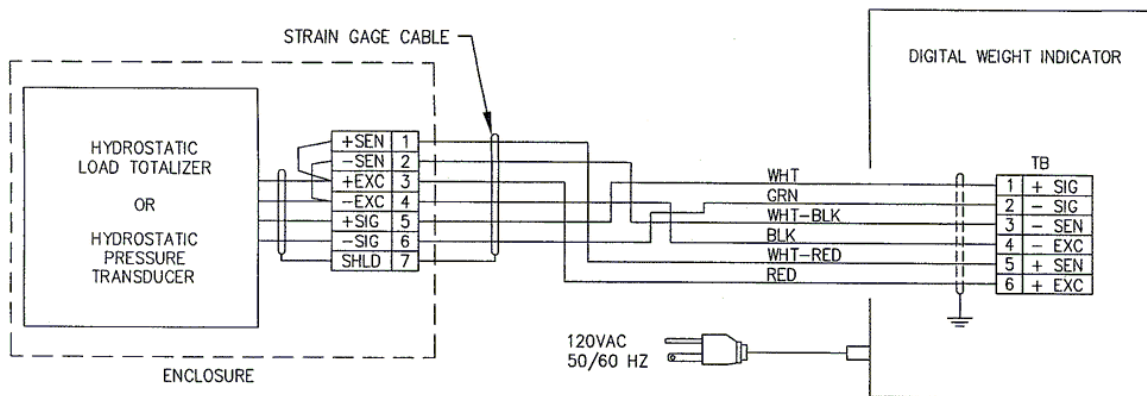

Once the instrumentation is connected and functional, the weigh system can be calibrated. Consult the indicator or process instrumentation manual to determine the correct calibration procedure.

## SECTION 4 - PERIODIC INSPECTION

Inspect the system after about one month of service. If there are no repairs needed, the system can be checked yearly. Keep a record of the inspection data. It can assist in troubleshooting if the need arises.

### **Making the Inspection:**

Check the following when inspecting the system.

1. Check For Proper Load Cell Gauging. To check this insert a feeler gauge into the gauging space. The measurement should be taken at the same location each time. A continuing downward trend of this measurement indicates a loss of fluid.
2. Check all fitting nuts visually. If there is evidence of leakage tighten the fitting nut slightly. DO NOT OVER TIGHTEN.
3. Check that the totalizer valves are tight.
4. Check for cell damage. If the load cell is damaged return it to the factory for overhaul.
5. Check that the staybars can rotate, are straight and have no movement along the centerline axis.

## SECTION 5 - SPARE PARTS

The following is a list of the spare parts we recommend the user/dealer keeps in stock to minimize down-time.

To order, please contact your dealer or the Emery Winslow Aftermarket Support.

Qty	Part #	Description
6	SS-202/3/4-1	Tube Nut and Ferrule Assembly
4	SS-200-6	Union for 1/8" tubing
25'	T18S-S	Stainless Tubing
1	BL-15Q	Quart of cell fluid
1	B-35548	Filling Tool with hose
1	PT-100	Nylon Purge Line
1	A-29595	Valve Wrench
1	See Loading Data Sheet	Totalizer Cell Diaphragm
2		Load Cell Diaphragm
1		Strain Gage Transducer

## SECTION 6 - TROUBLESHOOTING

### PROBLEM? - WHAT TO CHECK

Please check the following if there is a problem with the scale. If you have questions or need more information, please contact your dealer or Emery Winslow Aftermarket Support. Procedures to repair various problems are included in the following pages

1. Verify the scale is installed per the installation drawings.
2. Inspect the load cells, totalizer and all fitting nuts for evidence of leakage. Check the totalizer valves are closed. Repair as needed.
3. Check each load cell's gauging for proper gap. If needed, fill the cell to recommended gauging. No system recalibration is required when this is performed. Monitor the gauging over time and find the leak.
4. If the load cell will not gauge as cell fluid is added and the fluid is observed flowing out of the gauging area, the load cell or totalizer cell probably has a blown diaphragm. Replace the diaphragm- see the Diaphragm Replacement Procedure.
5. The vessel could be grounded. Correct to eliminate grounding. Check for rubbing against neighboring equipment. Check for direct connections between the vessel and ground, such as material build-up. Check all piping for specified flexing. Check that the staybars can move as specified.
6. Check the transducer excitation and signal voltages.

**Note:** When checking voltages, use a voltmeter with a high input impedance, 10 meg ohm or above.

The loading data sheet gives the millivolt output voltages at the tare (empty condition) and gross (full condition).

Check the excitation voltage and verify the excitation voltage of the indicator is the same as shown on the loading data sheet. If the excitation voltage is off by more than  $\pm 10\%$ , the digital indicator may need repair.

If the excitation voltage is within specification, check the signal voltage. Use the voltmeter's DC millivolt range and observe the correct polarity. The loading data sheet gives the transducer's output voltages for the tare and gross loading. Under partial loading, between tare and gross, the transducer's millivolt level will track the weight on the scale in a linear relationship.

7. Reseat each signal wire (White and Green) in the terminal block. The output signal strength from the transducer is a millivolt level (0.001 V) signal and is susceptible to interference from even the slightest corrosion.

# Service Information

Need Assistance with:

- Installation?
- Start-up?
- Calibration?
- Maintenance?
- Troubleshooting?

Let an Emery Winslow Service Technician help.

- 
- If you need immediate assistance with installation or calibration:  
Call 203-881-9333 x24 or email: [Parts@emerywinslow.com](mailto:Parts@emerywinslow.com)
  - If you are troubleshooting, and need fast technician assistance:  
Call 203-881-9333 x23 or email: [Service@emerywinslow.com](mailto:Service@emerywinslow.com)

Note: When calling, please have all the information from **one** of the labels below. We need this information to assist you quickly and accurately.

## Load Cell Label

 SEYMOUR, CT - TERRE HAUTE, IN MADE UNDER U.S. PAT. NO. 4,261,428	MOD. <input type="text"/>	S/N <input type="text"/>
	DWG. <input type="text"/>	CAP. <input type="text"/>

Located on the side of each load cell

## Totalizer Label

	<i>Emery Winslow Scale Company</i> <i>Seymour, CT Terre Haute, IN USA</i>	
Model <input type="text"/>	Job <input type="text"/>	
Drawing <input type="text"/>	Ref <input type="text"/>	
<i>Questions? Please call 203-881-9333</i>		
B-34821-7 MADE UNDER ONE OR MORE OF THE FOLLOWING PATENTS 3178937-3992946		

Located on the front of the valve block

## SECTION 7 - EVALUATION AND REPAIR PROCEDURES

### Totalizer Transducer Evaluation- Model 180/181/185 Totalizer

It is easy to make a quick diagnostic check of the transducer. The purpose of this check is to identify the source of a problem. These checks can be performed with a high quality voltmeter/ohmmeter.

**Note:** These tests can diagnose specific defects in a strain gauge transducer. Other defects, such as linearity or repeatability problems, may not be diagnosed with these checks. Only a factory evaluation can give a complete analysis of the strain gauge transducer's condition.

### Bridge Circuit Test- out of circuit

The bridge circuit test is used to test the condition of the bridge circuit. This test is performed with an ohmmeter.

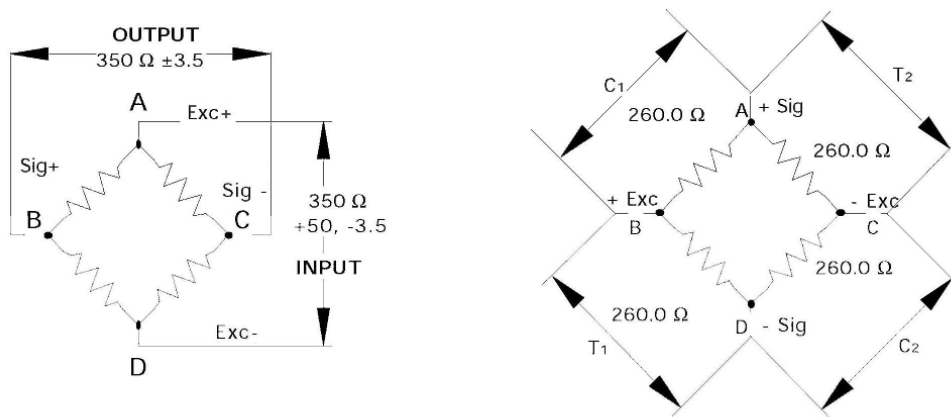

Measure the resistance across opposite corners of the bridge: the **Input** (+ and - Excitation) and the **Output** (+ and - Signal).

The following measurements should be made. The reading across:

1. the Red (A) and Black (D) leads should be 350 ohm. (+ 50 ohms, - 3.5 ohms).
2. the White (B) and Green (C) leads should be 350 ohm. ( $\pm 3.5$  ohm).

A reading outside the tolerance indicates a damaged strain gauge, possibly overload or water damage.

### Insulation Resistance Test- out of circuit

The bridge circuit test is used to test the condition of the bridge circuit. This test is performed with an ohmmeter.

**Note:** A megohm meter can yield more accurate results, but extreme care must be used in the testing process.

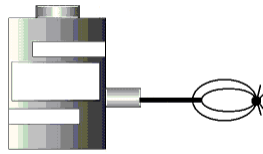

Connect the bridge wires (exc+, exc-, sig+, sig-) together and measure the resistance between the wires and the body of the strain gauge transducer. Do not include the shield wire when connecting the wires. If the resistance is above 5 megohms (5,000,000 ohms), the transducer is probably OK.

Low resistance (below 5 megohms) is often caused by moisture or pinched wires. The cause and extent of damage must be established at the factory to determine if it can be repaired.

**Note:** Some kinds of electrical shorts show up only when using a megohm meter or with voltages higher than most ohm meters can supply. When a megohm meter is used, its output voltage **MUST** be limited to 50 V. All corners of the bridge must be tied together or the bridge may be damaged.

### **Factory Evaluation**

If the strain gauge transducer is defective for reasons other than overload, return it to the factory for a detailed evaluation. Factory evaluation may show that the transducer is repairable.

## Totalizer Transducer Replacement- Model 180/181 Totalizer

This procedure is used to replace the strain gauge in the totalizer.

**IMPORTANT:** The Totalizer has two main parts; a grounded portion which starts at the base and continues up the stack, and a Floating Force Frame which sits on the top of the strain gauge and also continues up the stack. The Floating Force Frame floats between the grounded portion and transfers the pressure input from the cells to the strain gauge transducer. Lifting the Floating Force Frame while the Totalizer manifold fittings are open will introduce air into the totalizer stack. If this happens the entire Totalizer will need to be purged.

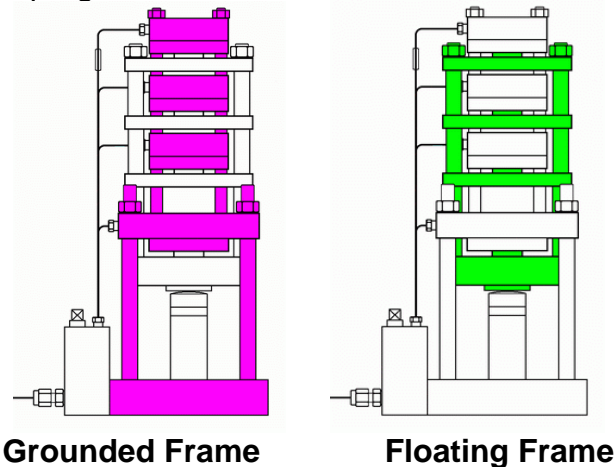

The easiest way to remove the strain gauge from the Totalizer is to completely remove the Totalizer from the enclosure. To remove the Totalizer from the enclosure, all load cell circuits must be drained of fluid, the tubing at the Totalizer manifold must be disconnected, and each of the tube fittings at the Manifold must be capped with a cap fitting. The strain gauge cable will also need to be disconnected from the terminal block.

**NOTE:** After starting this procedure, do not move or bump the totalizer until all the shipping plugs are installed on the manifold fittings.

1. To drain the system attach one end of the fill pump hose to the fitting and place the other end into a cup to catch the fluid. Open all valves. The tare weight of the scale will push the fluid out of each circuit.

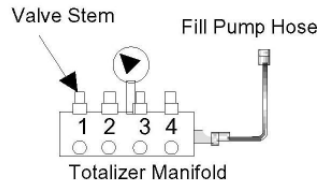

2. After draining the system, remove each of the tubes, and install the shipping plugs on the manifold fittings. The totalizer shipped from the factory with shipping plugs installed on the manifold fittings.

3. After noting the terminal block wiring, disconnect the strain gauge cable. Remove the screws holding the totalizer in the enclosure. These screws are usually accessible from the bottom of the totalizer enclosure.



4. Remove the totalizer from the enclosure and place it on a clean, dry, stable work surface.

5. Gently lift the floating force frame and place a 1/8" thick shim in the cell in the totalizer stack as shown. This will remove any load on the strain gauge. As long as each fitting on the manifold is capped with a shipping plug, no air will enter the totalizer.

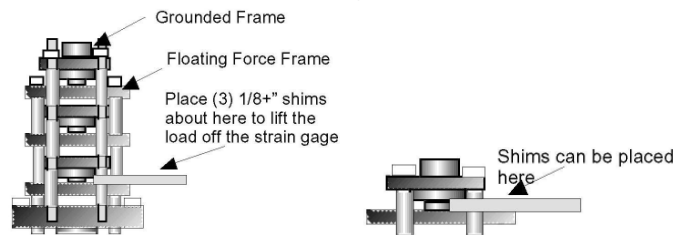

6. Loosen the socket head screw under the base of the totalizer with an allen wrench.

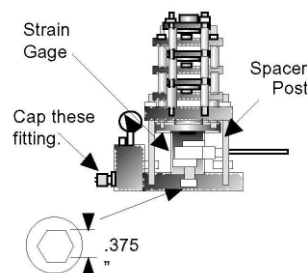

7. The strain gauge can be slipped out between the totalizer spacer posts.

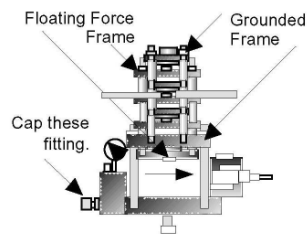

Emery Winslow utilizes special strain gauge transducers in the totalizer. It is strongly recommended only an authorized replacement strain gauge transducer be used. System performance can not be guaranteed and product warranty is void if a substitute strain gauge transducer is used.

8. Remove the load head button from the old strain gauge and screw it into the replacement unit.

9. Install the new strain gauge in the totalizer base and secure it with the socket head cap screw. Remove the shim from the stack.

10. Install the totalizer in the enclosure, attach the cable to the terminal block, and install the totalizer hold-down screws.

11. Remove each of the shipping plugs from the manifold fittings and install the tubes.

12. Follow the purging and gauging instructions to purge the air from the tubing and load cell and gauge the load cell to the required gap.

## Totalizer Cornering- Model 180/185 Totalizer

This procedure is used to adjust the totalizer to minimize slight variations of the totalizer input pressures.

**Note:** The Model 180 and 185 totalizers are adjustable. The Model 181 is not.

The Totalizer has two main parts; a grounded portion which starts at the base and continues up the stack, and a Floating Force Frame which sits on the top of the strain gauge and also continues up the stack. The totalizer cells are mounted to the grounded frame. When a pressure is input to the individual totalizer cell, the floating frame is pushed downward by the cell.

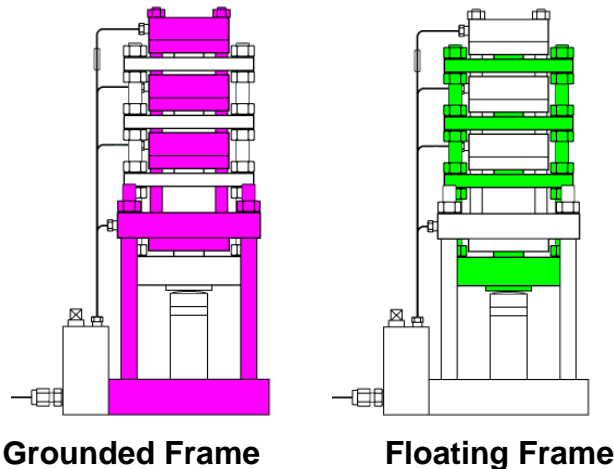

**Note:** This procedure is for a 4 cell totalizer. The procedure for adjusting totalizers with a different number of cells is similar.

**Note:** Totalizer cell 1 is not adjustable. All other cells are adjustable. The cells can be adjusted up or down by adjusting the 3 adjustment nuts on each piston plate.

**Procedure:** (The scale must be turned on to perform this procedure)

1. Using a known weight, of at least 10% of the scale's capacity, place the weight on the scale over the load cell. Use load cell 1 as the baseline. Establish if the weight reading is high or low, and by how much.
2. Find the load cell's corresponding totalizer cell. Each load cell is connected to a single totalizer cell. See the hydraulic schematic below.

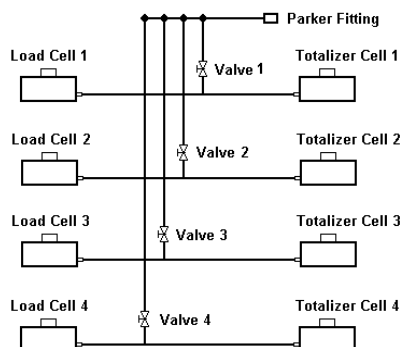

3. To adjust the individual totalizer cell, loosen the 3 lock nuts on the piston plate for the cell to be adjusted.

4. Turn the 3 adjustment nuts to adjust the weight reading for that cell. An upward adjustment increases the weight reading. A downward adjustment decreases the weight reading. Rotating a group of nuts by 1 flat will result in a change of about 0.1% of applied load. The maximum adjustment per cell is 4 flats, or about 0.4% of applied load.

**Note:** All 3 adjustment nuts on a piston plate must be turned by the same number of flats, in the same direction. This is extremely important to maintain scale accuracy.

5. After cornering adjustments are complete, tighten the 3 lock nuts for each piston plate.

6. Verify the displayed weight is the same when the known weight is placed on the corners and in the center.

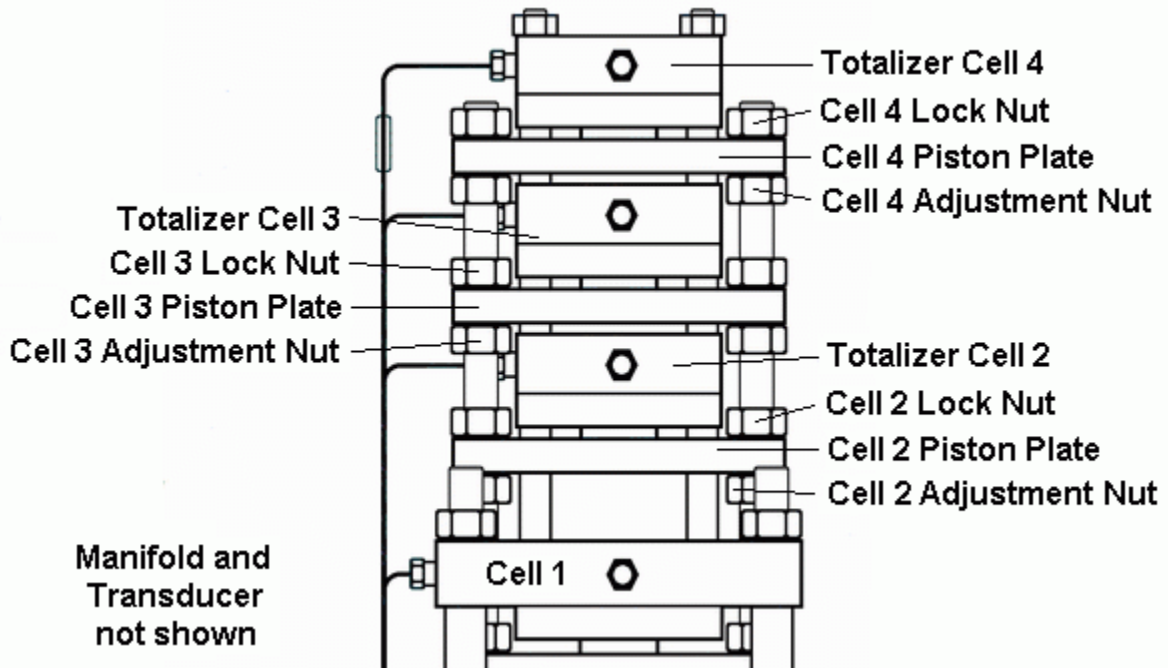

## Diaphragm Replacement- Model 102 Load Cell

This procedure is used to replace the load cell's diaphragm.

1. To drain the system attach one end of the fill pump hose to the fitting and place the other end into a cup to catch the fluid. Open all valves. The tare weight of the scale will push the fluid out from each circuit.

2. Lift the scale deck and remove the load cell from the scale assembly. Be careful to prevent both halves of the cell from separating as they are removed.



3. Place the cell in a clean dry area. Separate the load cell piston and head assembly.

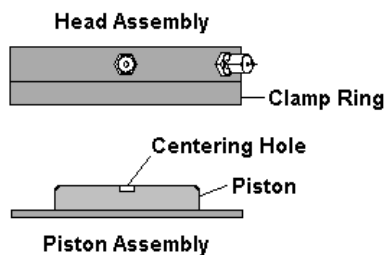

4. Turn the head assembly over and remove the screws from the clamp ring. This allows you to remove the diaphragm and the O-ring. Clean all parts and surfaces carefully.

5. The replacement diaphragm kit includes the diaphragm and O-ring. Always replace the O-ring when replacing the diaphragm.

**The following technique insures a smooth diaphragm convolution and proper centering button position after the two halves of the load cell are reassembled.**

6. Insert the new O-ring. A small amount of light oil may be used around the O-ring seat to help keep it in place during installation. Place the new diaphragm over the screw holes. Be careful not to move the O-ring from its position.

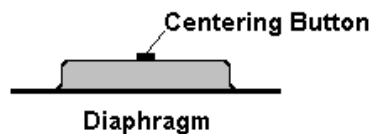

7. Position the clamp ring over the diaphragm while holding the diaphragm in place. Install and tighten the clamp screws. Tighten them to low torque first, then complete tightening to a torque value of 85 inch lbs.

8. Install the fitting cap on the purge fitting. Keep the other fitting open to atmosphere. Grasp the diaphragm centering button and pull outward gently to draw air into the load cell. Hold a finger over the open fitting to seal the air in.

9. Invert the piston assembly and position the centering button over the piston's

centering hole. Be sure the centering button enters the hole straight. With the finger over the fitting, press the two halves together. As the two halves press together, the pressure inside the diaphragm will increase and expand the diaphragm to fit properly around the piston.

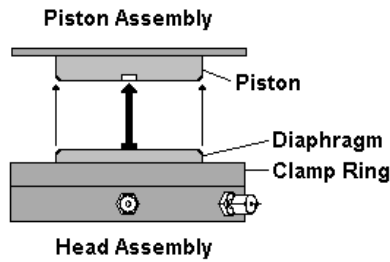

10. Gradually, release the finger over the open fitting to allow air to escape as you press the top half into the base. The two halves should be closed with a uniform set. If the cell is slightly cocked, it indicates the centering button is not properly installed.

The enlarged cutaway drawing of the load cell, shown below, illustrates the diaphragm convolution roll and centering button correctly set.

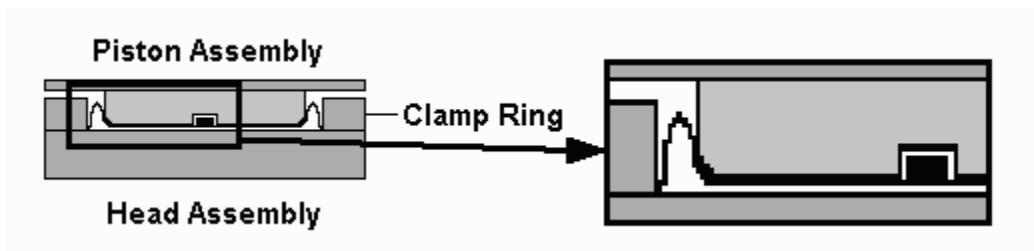

**Note:** A cocked centering button will produce non-repeatable and non-linear weight output from the load cell.

The load cell is now ready to be reinstalled into the scale assembly.

**Purge the Totalizer- Model 180/181/185 Totalizer  
(This does not have to be done for a new Totalizer.)**

This procedure is used to purge air from the totalizer. Refer to the illustration on the facing page for component locations.

Before attempting this procedure to purge a totalizer, be certain you understand how to purge the tubing and hydrostatic load cell, see Section 3.

A) Fill the filling tool with fluid. Connect the filling tool to the parker fitting at the right side of the totalizer manifold.

B) With all valves closed, pump fluid into the manifold until the relief valve "pops" and fluid comes out of the relief valve.

**Note:** Newer totalizers do not have a relief valve.

C) Remove the Cell #1 vent plug from the Totalizer Cell #1. This plug is located behind the pressure gauge; replace the plug with the purge tube. Place the free end of the purge tube into a clean container to catch the purged fluid.

**Note:** Some totalizers do not have a pressure gauge. Refer to the illustration on the next page for the location of the vent plug.

D) Open Valve #1 which corresponds with Totalizer Cell #1 and pump fluid through the purge tube until the flow is free of air bubbles.

**Tip:** Tipping the totalizer from side to side while tapping the cell lightly will facilitate air removal. Pump slowly.

E) Remove the purge tube and replace the Vent Plug #1 loosely. Pump again until fluid seeps out around the Cell #1 vent plug. Then tighten the plug per specifications.

F) Remove the fitting plug or tube from the Cell #1 fitting on the manifold and pump fluid to purge out any air bubbles trapped in the Cell #1 input passage.

G) Replace the fitting plug or tube on the Cell #1 manifold fitting and tighten while fluid is flowing out. Close Valve #1. Cell #1 and Cell #1 manifold fitting should now be purged of all air.

H) Repeat steps C through G for each corresponding totalizer cell and manifold fitting.

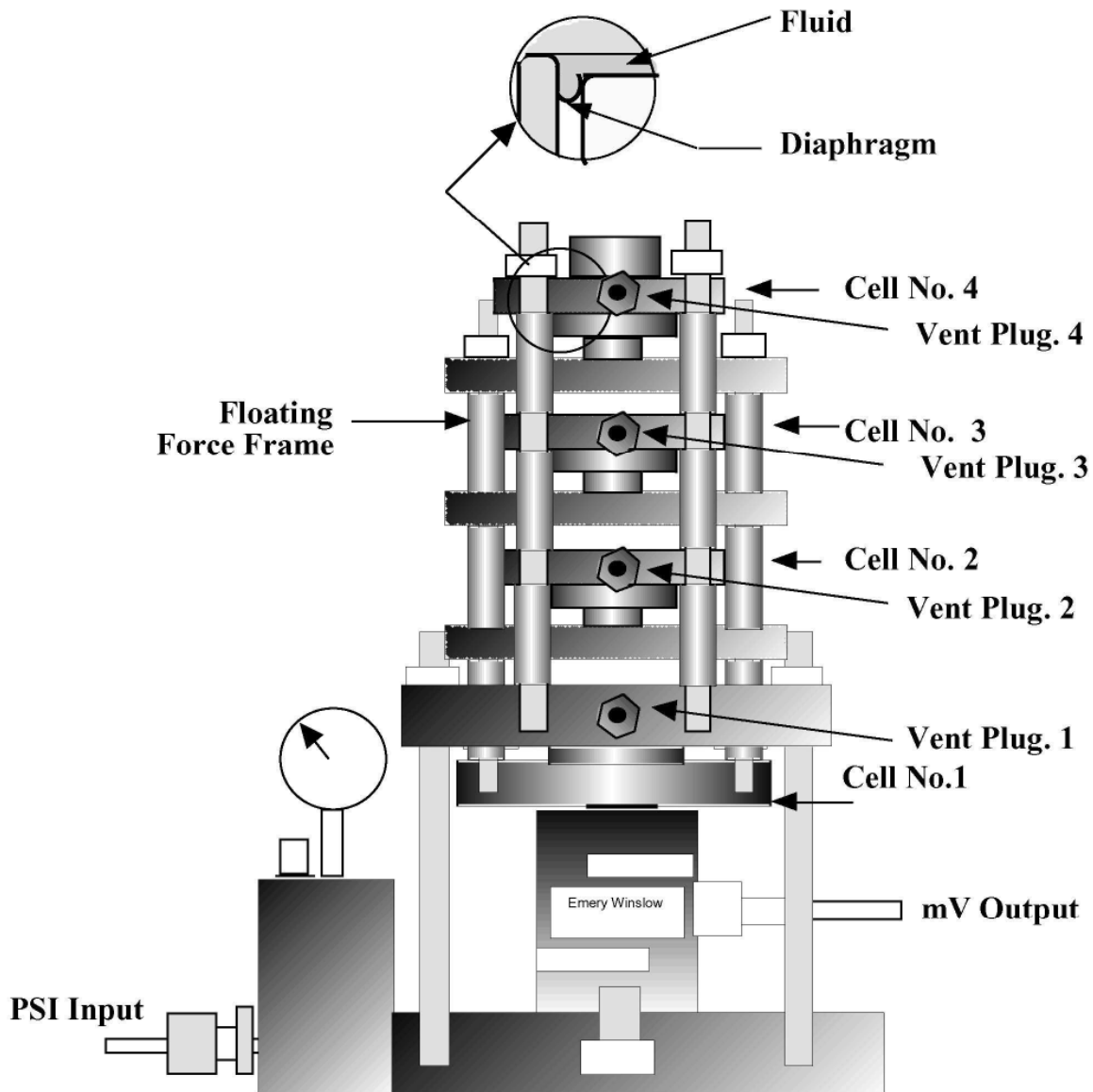

**Typical Four Cell Hytronic Totalizer (Non-adjustable type)**

**Input - four hydrostatic load cells - psi**

**Output - millivolt output**

Three load cell and two load cell systems have three and two input cells respectively, however, they still have mV output.

**EMERY WINSLOW SCALE COMPANY**

**73 Cogwheel Lane  
Seymour, CT 06483  
Ph – 203-881-9333  
Fax – 203-881-9477**

**[www.emerywinslow.com](http://www.emerywinslow.com)**

**Customer Service**

**1-800-891-3952**

**Sales Department – Ext 14 or 15**

**Service Department – Ext 24**