

ITEM NO.	DESCRIPTION	QTY	MATERIAL	UNIT WT.	PART NO.	SIZE	WT.
1	ANGLE	4	SS 304	12.7		ANGLE 6.00 x 4.00 x 0.38 x 64.75	274.1
2	CORNER PLATE	4	SS 304	8.2		STAINLESS FLAT BAR 0.38 x 6.00 x 10.00	27.3
3	NELSON STUD	16	CS		101-053-005	Ø0.50x5.31 TYPE H4L HILTI	

TOTAL WEIGHT = 301 lb

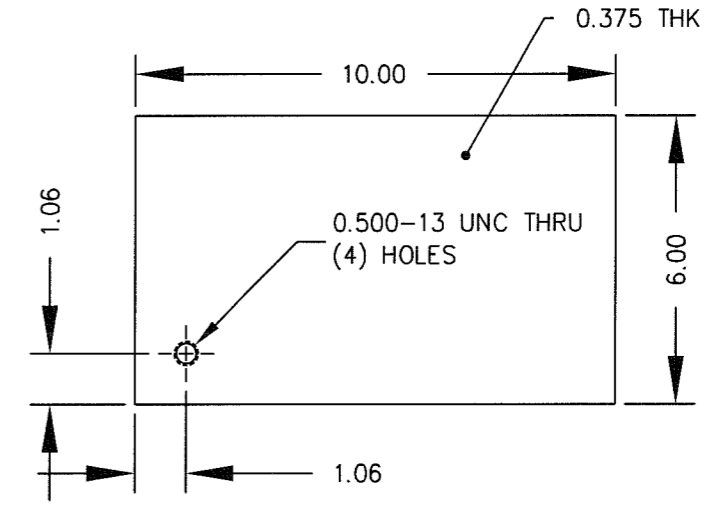

ITEM #2 CORNER PLATE
SCALE 1:2

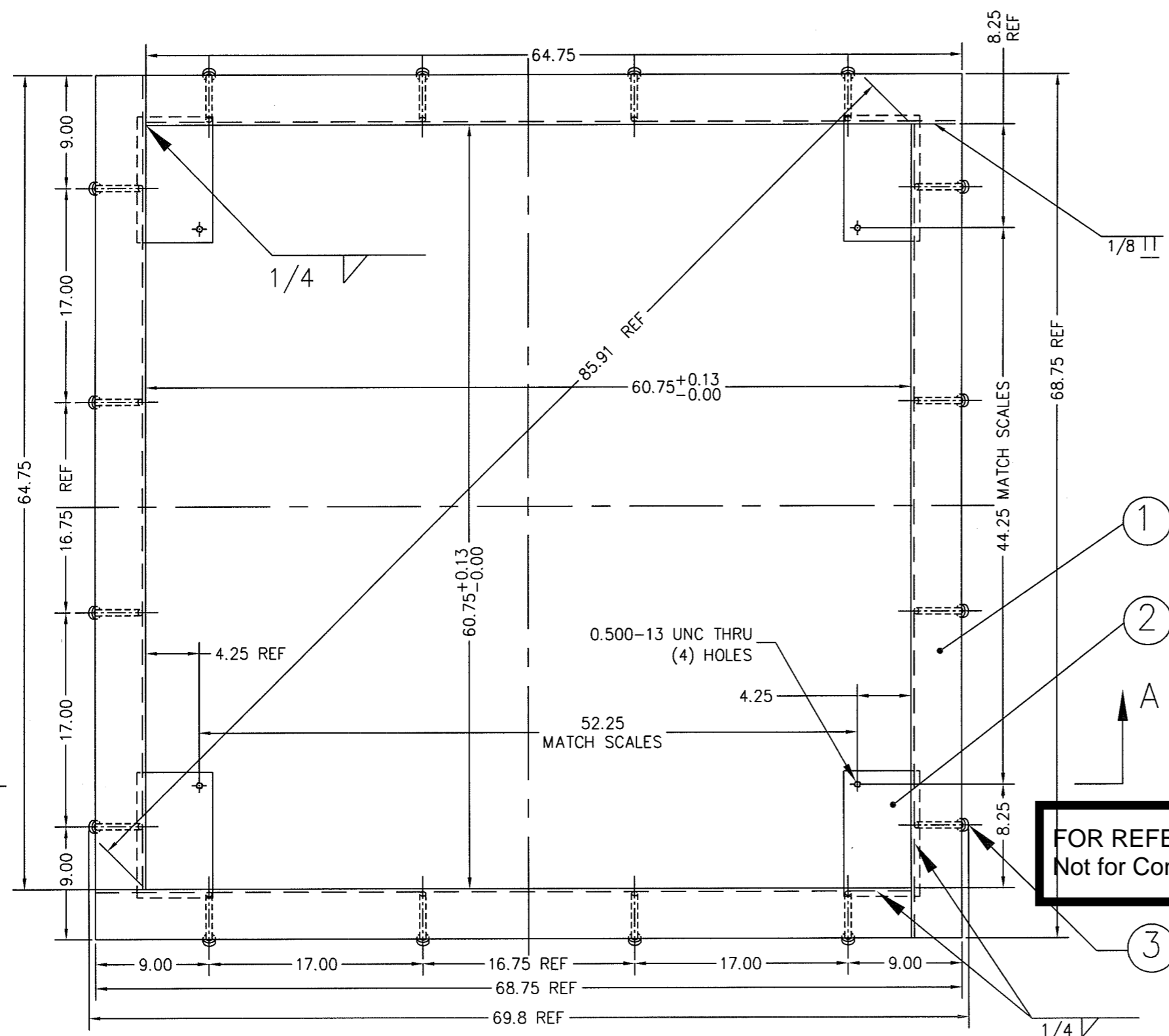
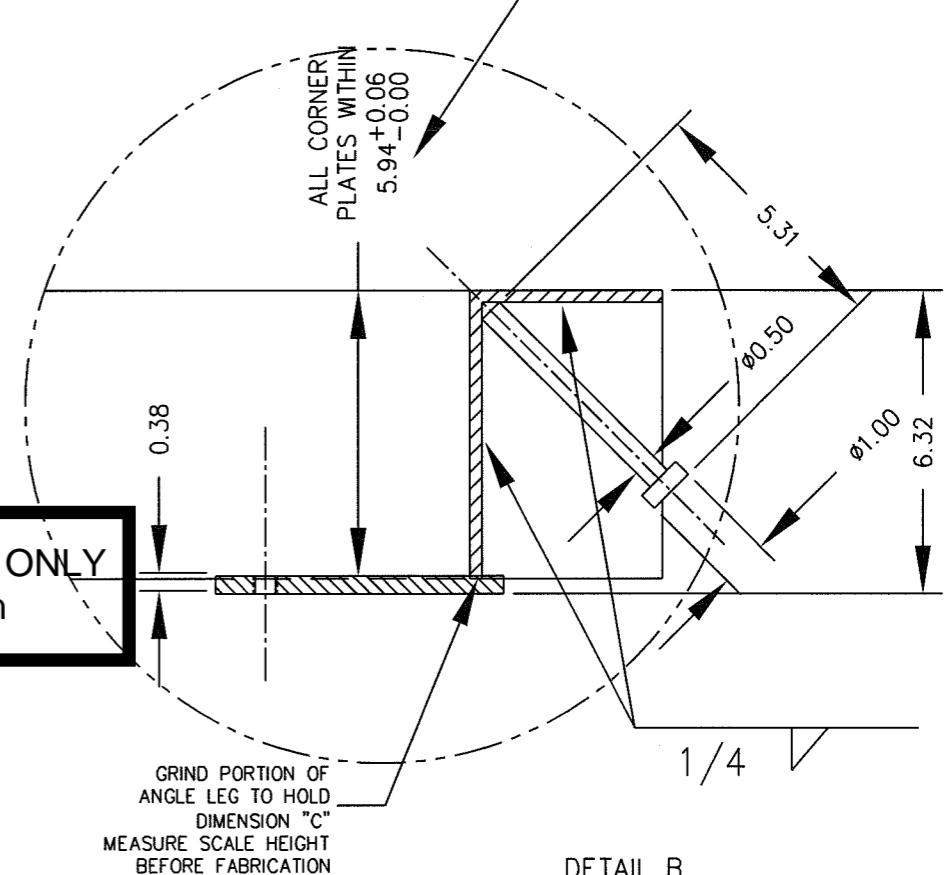

DETAIL B
SCALE 1:2

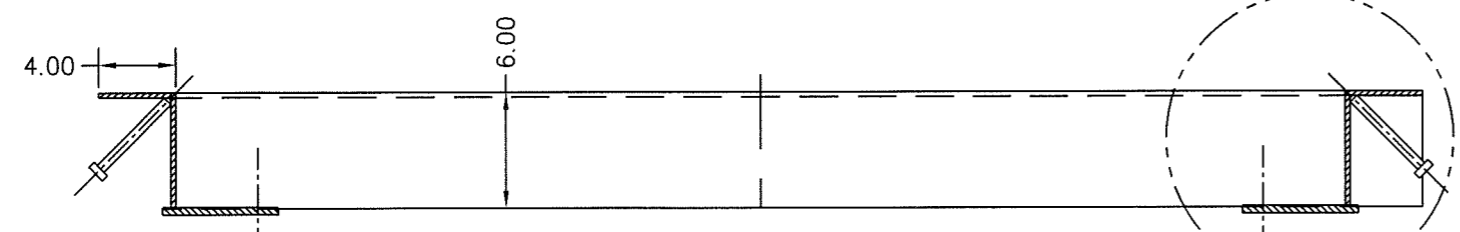

NOTES:
CONTROL WARPAGE DURING WELDING TO MAINTAIN FLATNESS AND SQUARE WITHIN .13

DEBURR ALL CORNERS AND EDGES				EMERY WINSLOW SCALE COMPANY SEYMOUR, CT U.S.A. TERRE HAUTE, IN.	
DIMENSIONS ARE IN INCHES. TOLERANCES UNLESS SPECIFIED OTHERWISE: MACHINING ±.015 FABRICATION ±.13				PIT FRAME 709-55-	
REV	DESCRIPTION	DATE	BY	SCALE	FIRST USED ON
				1:5	D-36014
THIS DRAWING IS THE PROPERTY OF EMERY WINSLOW SCALE COMPANY SEYMOUR, CONNECTICUT. THE INFORMATION CONTAINED HEREIN IS CONFIDENTIAL AND IS NOT TO BE USED OR DISSEMINATED TO OTHERS WITHOUT THE EXPRESS WRITTEN CONSENT OF EMERY WINSLOW SCALE COMPANY.				DATE: 06-30-04	REV
DRAWN BY: ACAD				SCALE	REV
CHECKED BY: AC01165				1:5	D-36014
LAYERS USED: ALL					