

NOTES:

1. Install four (4) anchor bolts, item 4, as per manufacturers specification.
2. Set base plate item 1 to proper height and level as specified, using greased leveling screws. Remove plate and apply a layer of grout in plate area slightly higher than required. Bolt base plate down to preset screws, squeezing out excess grout. Double check height and level. Remove leveling screws after approximately 2 to 3 hours.
3. Place scale assembly into pit with removable deck installed. Check for even gap between decks and pit coping all around scale.
4. Remove decks and transfer drill holes for four (4) anchor bolts, item 4. Install anchor bolts as per manufacturer's specification.
5. Tighten anchor bolts.

ITEM NO.	DESCRIPTION	QTY	MATERIAL	UNIT WT.	PART NO.	SIZE	WT.
1	BASE PLATE	4	SS 304	7.65	B-33340	(0.38 X 6 X 9)	20.5
2	LEVELING SCREW	12	CS			0.500-13UNC X 4.00	
3	NELSON STUD	18	CS		101-053-003	0.50 X 4.13 X H4L	OPT
4	ANCHOR BOLT	8	SS 304		KB11304SS112-512		HILTI OR EQUAL OPT
5	GROUT (NON-SHRINKING)	A/R				FIVE STAR PRODUCTS, INC., FAIRFIELD, CT., 06430	OR EQUAL OPT
6	COPING	2	SS 304			2 X 2 X 0.25 X 76.75	OPT
7	COPING	2	SS 304			2 X 2 X 0.25 X 60.75	OPT

AVAILABLE AS AN OPTION = OPT

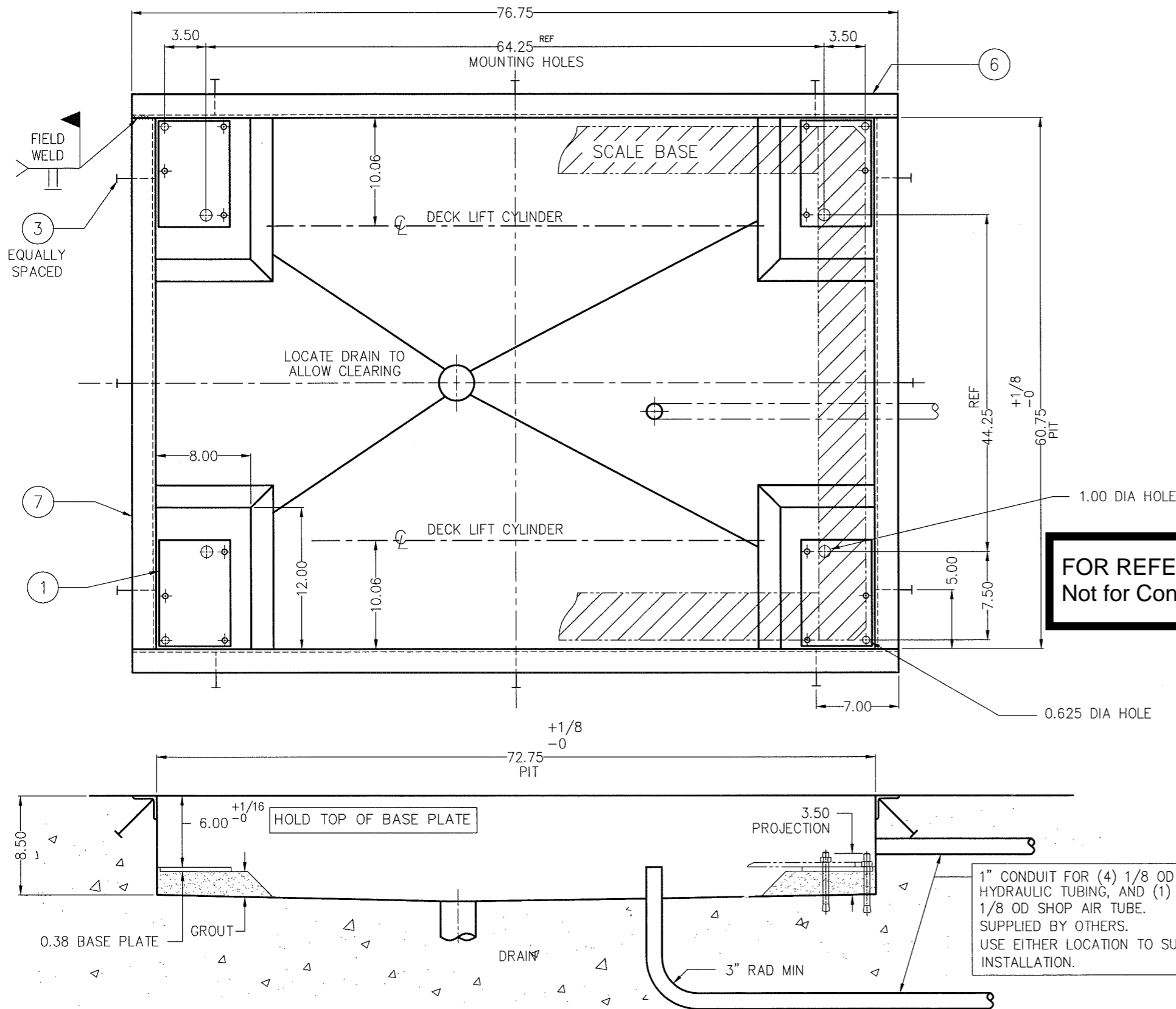

PITCHED FLOOR INSTALLATION

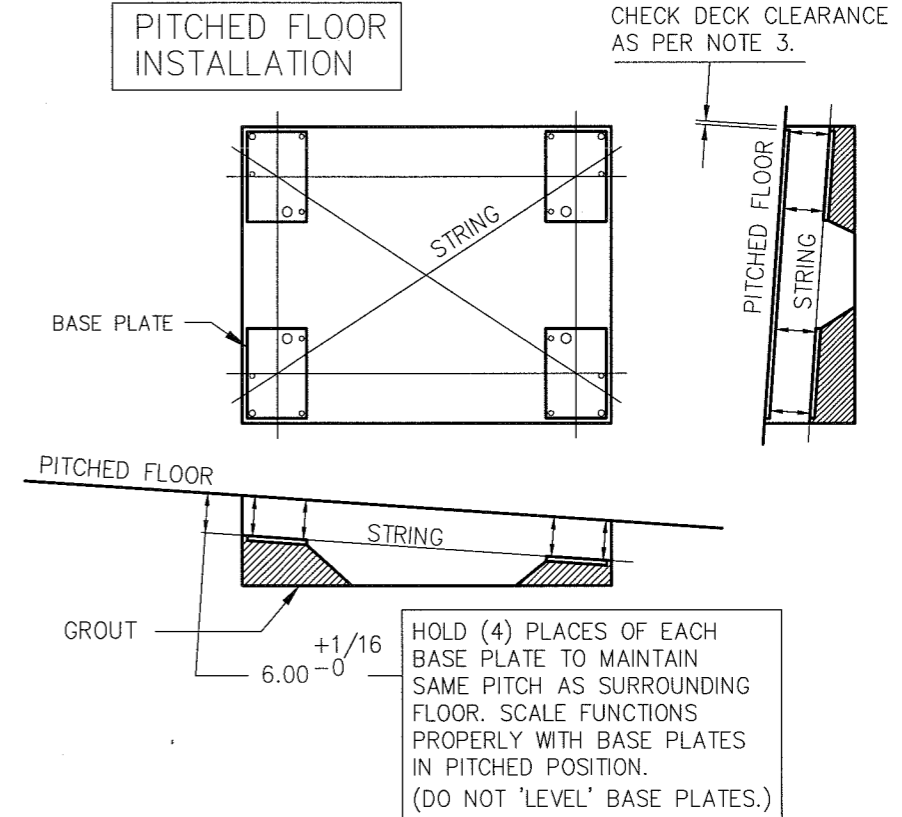

**FOR REFERENCE ONLY
Not for Construction**

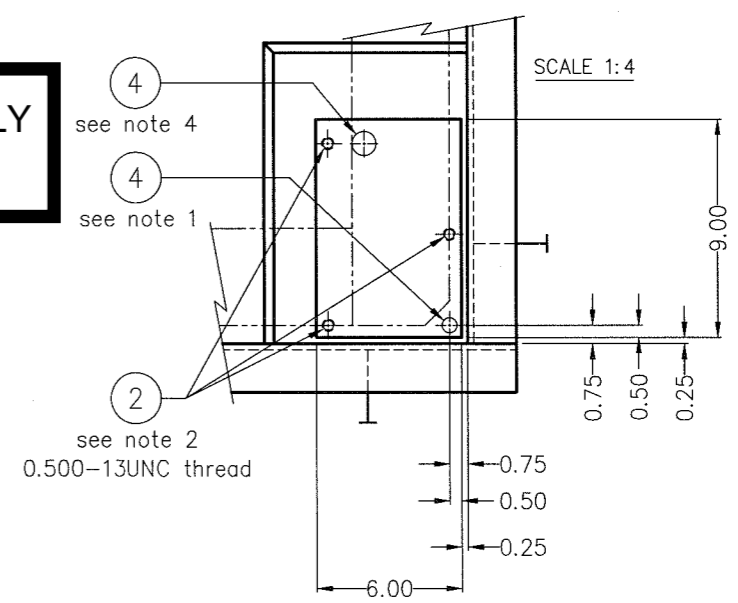

1" CONDUIT FOR (4) 1/8 OD HYDRAULIC TUBING, AND (1) 1/8 OD SHOP AIR TUBE. SUPPLIED BY OTHERS. USE EITHER LOCATION TO SUIT INSTALLATION.

ALL SHARP CORNERS AND EDGES TO BE BROKEN		EMERY WINSLOW SCALE COMPANY SEYMOUR, CT U.S.A TERRE HAUTE, IN.	
UNLESS OTHERWISE SPECIFIED DIMENSIONS ARE IN INCHES		PIT ARRANGEMENT MODEL 709-56 WITH PNEUMATIC DECK LIFTING	
A	ITEMS 2,4 CHANGED	11/96	JDS
LTR	REVISION	DATE	BY
THIS DRAWING IS THE PROPERTY OF EMERY WINSLOW SCALE COMPANY SEYMOUR, CONNECTICUT. THE INFORMATION CONTAINED HEREIN IS CONFIDENTIAL AND IS NOT TO BE USED OR DISSEMINATED TO OTHERS WITHOUT THE EXPRESS WRITTEN CONSENT OF EMERY WINSLOW SCALE COMPANY.			
DRAWN JDS		DATE 8/14/95	
CHECKED		DATE	
ACAD FILENAME: AC00298		SCALE: FIRST USED ON DRAWING NO. REV. NOT TO SCALE R D-34594 A	
LAYERS USED: 1,30,32			