

ITEM NO.	DESCRIPTION	QTY	MATERIAL	UNIT WT.	PART NO.	SIZE	WT.
1	HEAD	1	SS 303		B-24994-9		
2	LOAD CELL BASE	1	SS 316		C-29317-2		
3							
4	LOAD CELL CLAMP RING	1	SS 316		B-29318		
5							
6	SCREW CAP SOC HEAD	3	SS 304		10-24UNC X 0.88		
7	SCREW CAP SOC HEAD	6	SS 304		0.25-20UNC X 0.75		
8	DIAPHRAGM	1	BUNA/POLY		A-26557-1	1,500 PSI	
9	O-RING	1	VITON		NO. 11-039		
10	STAINLESS STEEL BALL	3	440		0.75 DIA		

ITEM NO.	DESCRIPTION	QTY	MATERIAL	UNIT WT.	PART NO.	SIZE	WT.
11	COMPRESSION SPRING	3	SS		A-16277		
12							
13							
14	MALE CONNECTOR	2	SS 316		SS-200-1-2	SWAGELOK OR EQUAL	
15	VENT PLUG	1	SS 316		SS-200-P	SWAGELOK OR EQUAL	
16							
17							
18							
19							
20							

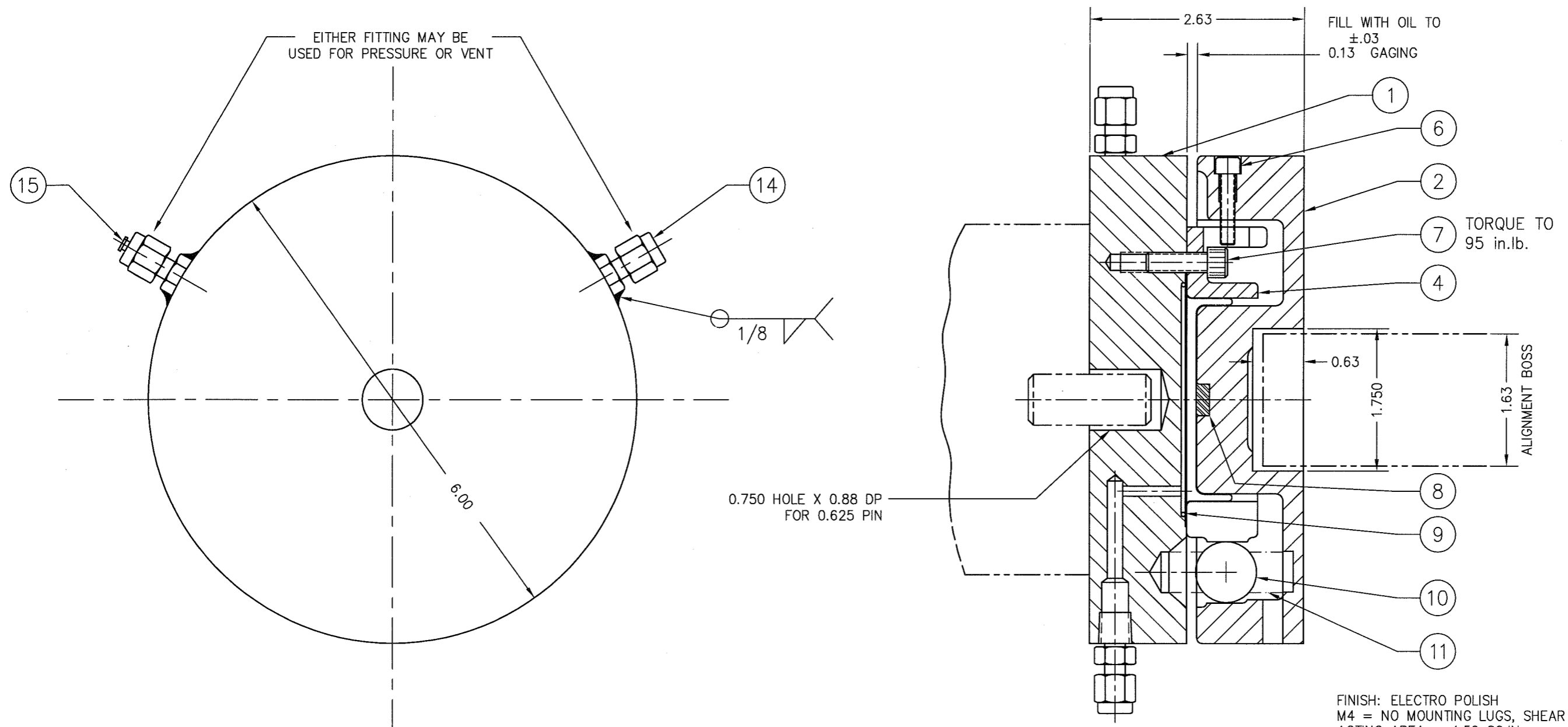

				ALL SHARP CORNERS AND EDGES TO BE BROKEN		EMERY WINSLOW SCALE COMPANY SEYMOUR, CT. U.S.A. TERRE HAUTE, IN.	
B	ITEM 2 C-29317-2 WAS C-29317 (3 MOUNTING LUGS REMOVED)	7/11/02	CBM	UNLESS OTHERWISE SPECIFIED DIMENSIONS ARE IN INCHES		SELF-CHECKING HYDROSTATIC COMPRESSION LOAD CELL ASSEMBLY MODEL 120S-5.0-SC-M4 5,000 LB CAPACITY	
A	REDRAWN ON CAD	10/30/97	JDS	DECIMALS FRACTIONS ANGLES			
LTR	REVISION	DATE	BY	.xx = ± .010 ± .xxx = ± .005 ±		SCALE FIRST USED ON DRAWING NO. REV. 1:1 R C-34634-2 B	
THIS DRAWING IS THE PROPERTY OF EMERY WINSLOW SCALE COMPANY SEYMOUR, CONNECTICUT. THE INFORMATION CONTAINED HEREIN IS CONFIDENTIAL AND IS NOT TO BE USED OR DISSEMINATED TO OTHERS WITHOUT THE EXPRESS WRITTEN CONSENT OF EMERY WINSLOW SCALE COMPANY.				DRAWN JDS DATE 10/97			
				CHECKED DATE			
				ACAD FILENAME: AC00471			
				LAYERS USED: 1-3			